

SECTION B

SERVICE MANUAL

LOW PRESSURE
PORTABLE FORCED AIR HEATER

SPARK PLUG IGNITION MODELS

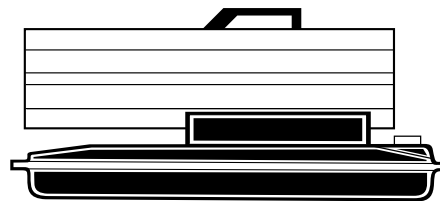
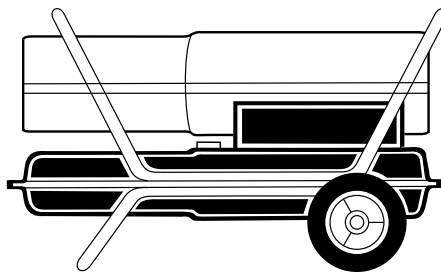

Spark Plug Ignition Models Service Manual

SAFETY INFORMATION

WARNINGS

IMPORTANT: Read this owner's manual carefully and completely before trying to assemble, operate, or service this heater. Improper use of this heater can cause serious injury or death from burns, fire, explosion, electrical shock, and carbon monoxide poisoning.

 DANGER: Carbon monoxide poisoning may lead to death!

Carbon Monoxide Poisoning: Early signs of carbon monoxide poisoning resemble the flu, with headaches, dizziness, and/or nausea. If you have these signs, the heater may not be working properly. **Get fresh air at once!** Have heater serviced. Some people are more affected by carbon monoxide than others. These include pregnant women, persons with heart or lung disease or anemia, those under the influence of alcohol, and those at high altitudes.

Make certain you read and understand all warnings. Keep this manual for reference. It is your guide to safe and proper operation of this heater.

- Use only kerosene or No. 1 fuel oil to avoid risk of fire or explosion. Never use gasoline, naphtha, paint thinners, alcohol, or other highly flammable fuels.
- Fueling
 - a) Personnel involved with fueling shall be qualified and thoroughly familiar with the manufacturer's instructions and applicable federal, state, and local regulations regarding the safe fueling of heating units.
 - b) Only the type of fuel specified on the heater's data plate shall be used.
 - c) All flame, including the pilot light, if any, shall be extinguished and the heater allowed to cool, prior to fueling.
 - d) During fueling, all fuel lines and fuel-line connections shall be inspected for leaks. Any leaks shall be repaired prior to returning the heater to service.
 - e) At no time shall more than one day's supply of heater fuel be stored inside a building in the vicinity of the heater. Bulk fuel storage shall be outside the structure.
 - f) All fuel storage shall be located a minimum of 25 feet from heaters, torches, welding equipment, and similar sources of ignition (exception: the fuel reservoir integral with the heater unit).
 - g) Whenever possible, fuel storage shall be confined to areas where floor penetrations do not permit fuel to drip onto or be ignited by a fire at lower elevation.
 - h) Fuel storage shall be in accordance with the federal, state, or local authority having jurisdiction.
- Never use heater where gasoline, paint thinner, or other highly flammable vapors are present.
- Follow all local ordinances and codes when using heater.
- Heaters used in the vicinity of tarpaulins, canvas, or similar enclosure materials shall be located a safe distance from such materials. The recommended minimum safe distance is 10 feet. It is further recommended that these enclosure materials be of a fire retardant nature. These enclosure materials shall be securely fastened to prevent them from igniting or from upsetting the heater due to wind action.
- Use only in well-vented areas. Before using heater, provide at least a three-square-foot opening of fresh, outside air for each 100,000 Btu/Hr of rating. This heater produces carbon monoxide, which is listed by the State of California as a reproductive toxin under Proposition 65.
- Use only in places free of flammable vapors or high dust content.
- Use only the electrical voltage and frequency specified on model plate.
- Use only a three-prong, grounded extension cord.
- Minimum heater clearances from combustibles:
Outlet: 8 Ft. Sides: 4 Ft. Top: 4 Ft. Rear: 4 Ft.
- Locate heater on a stable and level surface if heater is hot or running or a fire may occur.
- When moving or storing heater, keep heater in a level position or fuel spillage may occur.
- Keep children and animals away from heater.
- Unplug heater when not in use.
- When used with thermostat, heater may start anytime.
- Never use heater in living or sleeping areas.
- Never block air inlet (rear) or air outlet (front) of heater.
- Never move, handle, refuel, or service a hot, operating, or plugged-in heater.
- Never attach duct work to front or rear of heater.
- Approved by the New York City Fire Department under certificate of approval #4803, #4860, #4908, or #4909. To be used only at construction sites in accordance with applicable New York City Codes, Regulations, Rules, Directives, Permits, etc.
- **Warning to New York City Residents** For Use Only At Construction Sites in accordance with applicable NYC codes under NYCFD certificate of approval #4803, #4899, #4908, #4909, or #4934.

Spark Plug Ignition Models Service Manual

TABLE OF CONTENTS

General Information

I. Arrangement of Manual	3
III. Service Preparation	3
IV. Tools Required	4
V. Parts	4

Specifications

I. General Specifications	
1. Fuel Selection	5
2. Electrical	5
3. Ventilation	5
4. Heater Sizing	6
Heater Performance Specifications	6

Component Operation

I. Air System	
1. Air Pump	7
2. Air Filters	7
3. Nozzle	7
II. Electrical System	
1. Motors	7
2. Solid State Relay	8
3. Safety Control/Photocell	8
4. Electronic Ignitor	9
III. Fuel System	9
IV. Combustion System	9
V. All Systems Working Together	9

Troubleshooting

I. Safety Requirements	10
II. Cautions	10
III. Using the Ohmmeter	
1. Setting Up the Ohmmeter	10
2. Calibration	10
IV. Diagnostic Charts	10

Diagrams and Charts

I. Wiring Diagrams	23
II. Motor Resistance Chart	23

GENERAL INFORMATION

I. ARRANGEMENT OF MANUAL

This manual contains information and service procedures to assist the service technician in understanding and correcting problems on DESA International oil-fired portable forced air heaters. The first section of the manual contains basic information concerning the operation of the different components in the heater. This information should be reviewed by service personnel to provide a basic understanding of how the components function in the working system. Section four of this manual is intended to provide a quick reference concerning conditions which result in customer complaints. These procedures will help the service technician quickly diagnose a malfunctioning heater. The illustrations in this manual may not necessarily depict the actual heater model, and are intended for reference ONLY.

III. SERVICE PREPARATION

A clean work area at the start of each job is essential for efficient service work. Heaters which are extremely dirty should be cleaned prior to service. Cleaning will occasionally uncover the problem area. Tools needed for the job should be obtained before work is started. Delays resulting from locating tools result in lost time and wages.

Clean fuel should always be used when testing heaters. Many problems are often traced to the use of the wrong type of fuel or dirty fuel.

Use caution and common sense when working on a heater. Always remember that kerosene is flammable, electrical parts can result in the potential shock and the heater parts are hot during operation, which could result in burns if one is not careful.

Spark Plug Ignition Models Service Manual

IV. TOOLS REQUIRED

In addition to common hand tools, the service shop should have the following tools and instruments for proper repairing of the heaters. These instruments will be referred to throughout this manual.

<u>INSTRUMENT</u>	<u>RANGE</u>	<u>PART NUMBER</u>
Pressure Gauge	0-15 PSI	HA1180
Feeler Gauge	.001 to .1 inch	None*
Volt Ohmmeter	RX1/AC 250V	None**

*Available at any auto parts store.

**Available at most electronic stores.

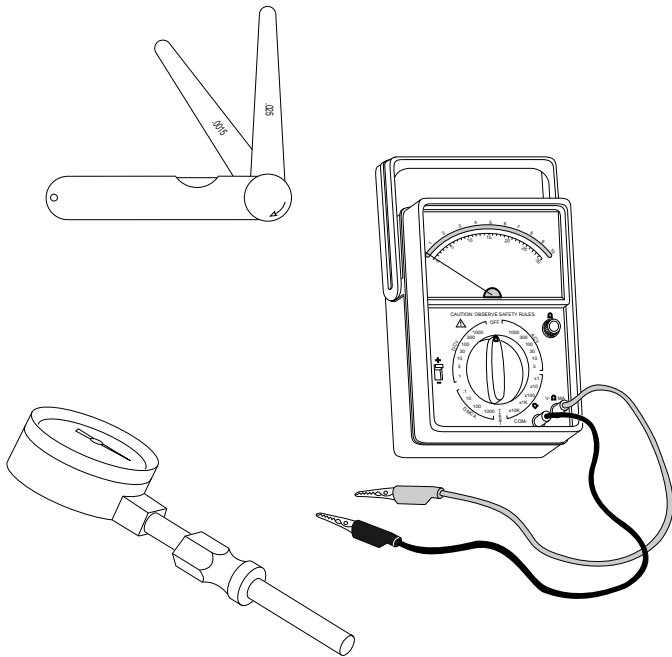

V. PARTS

Accessories

In addition to the standard parts we now offer parts kits. Listed below are the item numbers and the accessory description

<u>ITEM NUMBER</u>	<u>ACCESSORY</u>
HA1180	Air Gauge/All Models
HA1210	Thermostat/Forced Air & LP Forced Air
HA1202	Heavy Duty Wheel Kit Fits: 30, 35, 40, 50, 55, 70 Models
HA1206	Wheel Kit Fits: 30, 35, 40, 50, 55, 70 Models
HA2203	Rear Handle Fits: 100, 110 Models
HA2204	Rear Handle Fits: 150, 155, 165, 200 Models
HA2210	Filler Neck Screen
PP203	Flame Out Safety Control
PP204	Rotor Kit 1/2"
PP206	Nozzle (35, 40 Models)
PP207	Nozzle (50 Models)
PP208	Nozzle (70 Models)
PP209	Nozzle (100, 110 Models)
PP210	Nozzle (150, 155 Models)
PP211	Spark Plug (70, 100, 150, 155, 165, 200 Models)
PP212	Spark Plug (35, 50 Models)
PP213	Air Filter Kit (30, 50, 70 Models)
PP214	Filter Kit (100, 110, 150, 155, 165, 200 Models)
PP205	Rotor Kit 5/8"
PP218	Nozzle (55 Models)
100735-10	Nozzle (165 Models)
PP216	Photocell
PP217	Pump Adjustment Kit

Spark Plug Ignition Models Service Manual

SPECIFICATIONS

I. GENERAL SPECIFICATIONS

1. Fuel Selection

One of the most critical specifications for trouble-free operation is the use of a clean, acceptable fuel. Listed below are guidelines and comments concerning operation of heaters with different fuels.

<u>RECOMMENDED FUELS</u>	<u>COMMENTS</u>
Kerosene Fuel Oil No.1 Jet "A"	Best overall results. Minimum odor and minimum maintenance. No additives necessary for cold weather operation.
<u>ALTERNATE FUELS</u>	<u>COMMENTS</u>
Fuel Oil No. 2 Diesel No. 1 Diesel No. 2	Noticeable increase in odor. Requires frequent maintenance of fuel filter, nozzle and spark plug. Requires a winterizing additive at temperatures below 20°F

2. Electrical

The heater must be connected to a standard electrical outlet (120V/60HZ). For safety, all heaters are equipped with a three prong power cord, which must be grounded. When selecting an extension cord for heater usage, the following chart should be used in determining wire size.

<u>LENGTH OF CORD</u>	<u>WIRE SIZE (AWG)</u>
100 Ft.	No. 14
200 Ft.	No. 12
300 Ft.	No. 10
400 Ft.	No. 8
	No. 6

3. Ventilation

The heater should be used only in well-ventilated areas. As a rule, the following minimum requirements should be followed.

<u>HEATER SIZE (BTU)</u>	<u>SQUARE FOOT OPENING</u>
30,000/35,000	1.0 Sq. Ft.
50,000/55,000	1.6 Sq. Ft.
70,000	2.1 Sq. Ft.
100,000/110,000	3.2 Sq. Ft.
150,000/155,000	4.5 Sq. Ft.
165,000	5.0 Sq. Ft.
200,000	6.0 Sq. Ft.

The above is based on ventilation requirements of at least a 3 sq. ft. opening per 100,000 BTU. If possible, it is better to provide cross-ventilation to achieve better air movement.

Spark Plug Ignition Models Service Manual

4. Heater Sizing

The user should be aware of the proper size heater needed for a particular application. It is easy to see that a 30,000 BTU heater would not heat a large warehouse, but the question is sometimes asked "What size heater should I use?" A simple formula that can be used to determine heater BTU requirements follows:

Cu. Ft. of Area X .133 X Desired Temp. Rise °F = BTU Size Needed.

Example:

Area: 50' X 25' X 10' = 12,500 Cu. Ft.

Desired Temp. Rise: 30°F

12,500 (Cu. Ft.)

X .133 (Factor)

1662.5

X 30 (Temp. Rise)

49,875 (Proper Heater Size)

ANSWER: A 50,000 BTU heater should be selected for this application.

II. HEATER PERFORMANCE SPECIFICATIONS (SPARK PLUG MODELS)

Reddy Heater Brand Technical Service Heater Performance Data

Heater Model	BTU Rating	Pump P.S.I. ± 1	Nozzle Part No.	Nozzle Flow GPH ±5%	Motor Part No.	Motor R.P.M.	Motor Horsepower	Motor Start Relay or Solid State Relay	Fuel Tank Capacity (Gal)	Hot Air Output (C.F.M.)	AMPS (Running)	Spark Plug Gap (inches)
R30	30,000	3.0	M29681	0.23	102001-01	1725	1/15	Not Used	3.0	165	2.8	.050/.060
R35, R35A, R35B	35,000	3.0	100735-02	0.27	102001-01	1725	1/15	Not Used	3.0	165	2.8	.050/.060
R50, R50A R50B	50,000	3.6	M50597	0.37	102001-01	1725	1/15	Not Used	4.0	165	2.9	.050/.060
R55	55,000	3.4	100735-17	0.40	102001-01	3450	1/15	Not Used	5.0	175	2.9	.050/.060
R70, R70A R70B, R70BT	70,000	4.0	100235-04	0.52	097308-02	3415	1/8	M25061-1	5.0	250	3.0	.050/.060
R100, R100A	100,000	4.0	100735-06	0.74	097300-02	3450	1/5	097061-01	9.0	480	5.5	.070/.080
R110	110,000	4.0	100735-06	0.80	097300-02	3450	1/5	097061-01	9.0	490	5.5	.070/.080
R150B, R150D	150,000	3.4	100735-07	1.10	097300-02	3450	1/5	099061-01	13.5	550	5.0	.070/.080
R165	165,000	5.4	100735-10	1.10	102001-07	3450	1/4	097061-01	13.5	575	5.0	.070/.080
R200	200,000	6.0	100735-13	1.4	102001-07	3450	1/4	097061-01	13.5	600	4.5	.105/.115

102482-01 Transformer or Electronic Ignitor will apply to all models for service.

Spark Plug Ignition Models Service Manual

COMPONENT OPERATION

I. AIR SYSTEM

1. Air Pump

The heater's air pump consists of a rotor with four carbon blades rotating inside a pump body. The rotor is driven directly by the motor and is attached to the motor shaft by means of a plastic insert. As the motor rotates, the carbon blades travel outward rubbing against the inside surface of the steel pump body. The rotor's position inside the pump body is such that it is not concentric with the pump body and a .003/.004 of an inch gap is set at the uppermost quadrant. As the motor rotates, the air between the blades is compressed and routed to the nozzle through the air line.

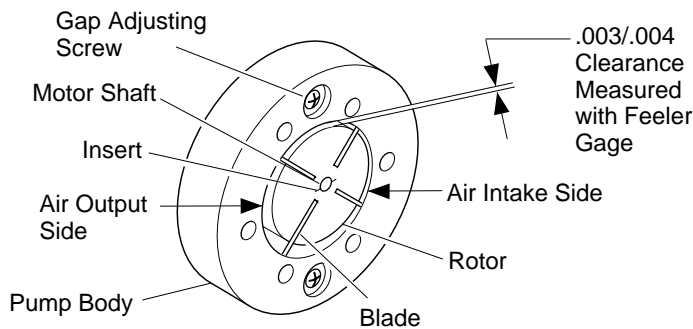

Direction of Rotation-Clockwise

2. Air Filters

The air filtering system consists of an air input filter and an air output filter. The air input filter is located at the right rear of the motor and its purpose is to filter all incoming air prior to entering the air pump. The filter design is such that it can be cleaned in a mild, soapy solution, thoroughly dried and used over again. The air output filter is located under the plastic end cover. This filter's purpose is to prevent any carbon dust (from rotor or blade wear) from entering the air passages in the nozzle. This filter is non-cleanable and should be replaced when considerable buildup of carbon dust is observed. (See drawings below).

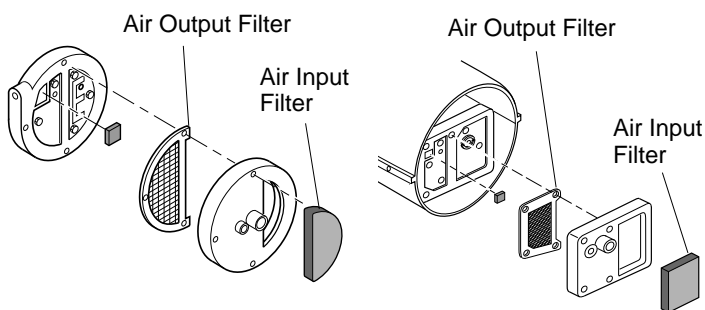

30,000, 35,000, 50,000, 55,000, 100,000, 110,000, 150,000, and 70,000 BTU Filter System **155,000, 165,000, and 200,000 BTU Filter System**

3. Nozzle

As mentioned previously, the purpose of the air pump is to compress air and deliver it to the nozzle. The compressed air, as it travels through the nozzle, creates a negative pressure that extends back through the center of the nozzle. This negative pressure lifts the fuel from the fuel tank. The fuel from the fuel tank and the compressed air are mixed at the nozzle which results in a very fine mist of fuel being sprayed into the combustion chamber. The air pump/nozzle combination eliminates the need for a conventional type fuel pump. It is important for the service technician to understand the nozzle operation. In many cases concerning improper operation of a heater, the problem is the result of a seal leak or a restriction (dust/dirt) being present within the nozzle. It should also be pointed out that each model heater requires different nozzles due to different fuel flow rates.

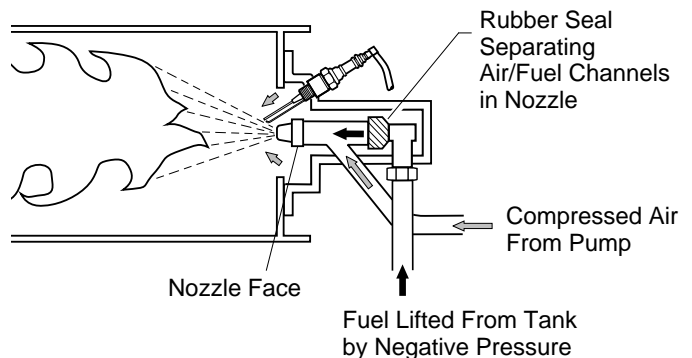

I. ELECTRICAL SYSTEM

1. Motors

The motors used on the low pressure heaters are fractional horsepower motors ranging from 1/15 HP on the smallest heater to 1/4 HP on the largest heaters. The motors used can be grouped into two categories. The first category is the shaded pole motor. The shaded pole motor contains a single winding and does not require an external start relay for operation.

These motors are easily identified by observing that only two wires (usually red and white) are necessary for operation.

The second category is the split-phase motor. This motor contains two separate windings. The first winding being the auxiliary or start winding and the second being the main or run winding. This motor requires an external means of switching the power off to the auxiliary winding after the motor reaches a predetermined speed. This power off switching is accomplished by a motor start relay or solid state relay. These motors are identified by observing that three wires (black, red and white) are routed from the motor.

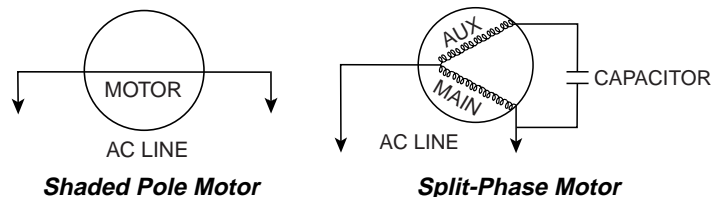

For replacement parts contact:

www.PartsFor.com

Spark Plug Ignition Models Service Manual

2. Solid State Relay

Applicable models use 097061-01 Solid State Relay.

The solid state relay is used to de-energize the start winding on split-phase motors. As mentioned in the Motor Section, remember that split-phase motors have both an auxiliary (start) and a main (run) winding. For proper motor operation, both the auxiliary and main winding are energized during start up. After the motor starts and reaches approximately 80% of rated speed, the auxiliary winding must be de-energized to prevent overheating. This is accomplished by the use of a solid state relay. The operation of the relay functions as a positive temperature coefficient resistor. When voltage is applied to the motor, the main and auxiliary windings are energized as current flows through the solid state relay which is connected in series with the auxiliary winding only. The resistance is increased over time in the solid state relay where it eventually rises to the point that theoretically no current flows, de-energizing the auxiliary winding.

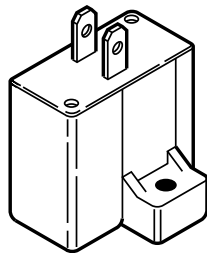

Solid State Relay

3. Safety Control/Photocell

The safety control circuit consists of a photocell (light sensitive cell) and a safety control. The photocell is used to sense the presence of light inside the combustion chamber. The photocell varies its electrical resistance in relation to the light rays which contact its surface. When the heater is operating properly, the photocell sees sufficient and proper color light, which keeps its resistance low. When the photocell does not sense the proper color or amount of light, the resistance of the photocell increases and forces an electrical current to flow through the solid state trigger circuit. The current flows into the circuit breaker and heats a metal bar causing the bar to warp (bimetal). The warpage releases the spring loaded reset button, which breaks all power to the heater. As a service technician, it is important to understand the operation of the safety control. In the past, it has been the single most misdiagnosed part of the heater. It is suggested that all controls be checked per instructions listed in the Troubleshooting Section, prior to replacement.

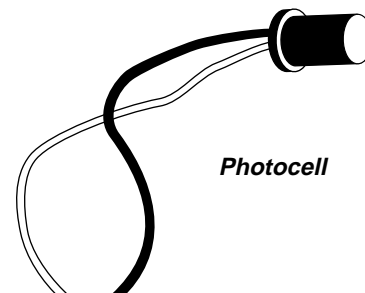
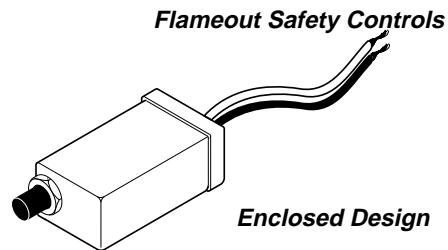

Spark Plug Ignition Models Service Manual

4. Electronic Ignitor

All models use 102482-01 Electronic Ignitor Kit.

The electronic ignitor operates on 120V/60Hz. It delivers approximately 6,000 volts average to the spark plug causing the kerosene sprayed from the nozzle assembly to ignite. The ignitor operates on a pulse basis. The ignitor has no internal service parts and must be replaced when found defective.

Note: It is important for the service technician to be cautious when working with the electronic ignitor due to its high voltage output.

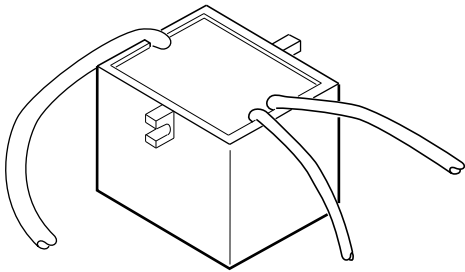

III. FUEL SYSTEM (Fuel filters)

There are several types of fuel filters used on different model heaters. The filters are always located in line with the fuel pickup tube. The purpose of the filter is to eliminate the possibility of dirt, dust, etc. from entering the nozzle and restricting the flow. The filters should be inspected and cleaned whenever a heater is brought in for service. It is also important that the bottom of the tank be inspected for sedimentation or dirt buildup. The filter's design is such that a possible restriction in the filter screen can be present during operation and be dislodged back into the tank when the heater is shut off.

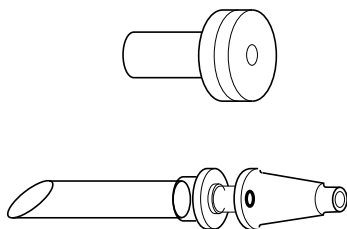

IV. COMBUSTION SYSTEM (Burner Head)

The burner head is mounted to the rear of the combustion chamber. The purpose of the burner head is to meter and mix the amount of air entering the chamber to obtain proper combustion characteristics. The nozzle is mounted in the center of the burner head and is surrounded by fins, so that the amount of air entering the chamber from the burner head is equal and balanced. The size of the slots in the burner head differ between models.

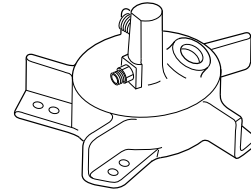

V. ALL SYSTEMS WORKING TOGETHER

There are four basic systems within the heater: the fuel system, the air system, the electrical system and the combustion system.

An air pump (A) on one end of the motor shaft forces air through the air line (G) and out the burner nozzle (I). The moving air creates a pressure differential in the burner head (N) causing fuel to be drawn from the tank (J). The fuel-air mixture is sprayed into the combustion chamber (L) in a fine mist.

Addition air is supplied to the combustion chamber by a fan (O) to enter the combustion chamber where it mixes with the air and fuel from the nozzle. The remaining air is directed around and over the combustion chamber. This air mixes with the heated air from the combustion chamber and is ejected as a jet of clean, heated air (K).

The ignition system consists of an electronic ignitor (E) and spark plug (M). The electronic ignitor increases the input voltage to a very high potential, which causes an arc to jump between the electrodes of the spark plug. The arc is used to ignite the fuel and air mixture within the combustion chamber. The arc fires constantly during operation.

In the safety circuit, the flame sensor detects the presence of light from the flame inside the combustion chamber.

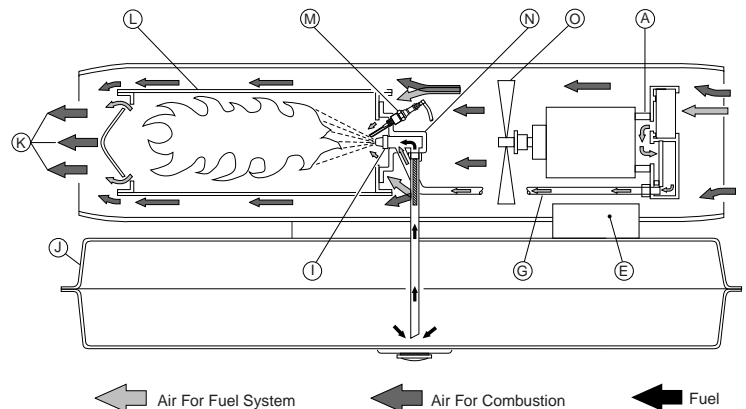

Spark Plug Ignition Models Service Manual

TROUBLESHOOTING

I. SAFETY REQUIREMENTS

This service manual is intended for use by individuals with an adequate knowledge of electrical and mechanical skills. Attempts to repair this heater by individuals without those skills can result in personal injury, as well as property damage.

II. CAUTIONS

1. Before servicing, disconnect the heater from the electrical power source by removing the electrical plug from the wall receptacle.

Note: When certain tests require electrical power to be applied, connect electrical power only for the time necessary to complete the test.

2. Do not bypass safety devices.
3. If replacement parts are necessary, do not substitute with non-factory parts (use only factory authorized replacement parts).
4. Make sure all electrical connections are secure and all harness leads are in place prior to connection to electrical power source.

III. USING THE OHMMETER

Continuity Check: Throughout the diagnostic procedures, you will be required to check continuity of the electrical circuits. A brief description of how to set up the ohmmeter for these tests follows.

1. **Setting Up the Ohmmeter**
 - A. use a small screwdriver to adjust the plastic screw on the zero "0" mark to the far left of the scale.
 - B. With the battery installed, set the switch to the "RX1" position.
 - C. Plug in test wires and use insulated alligator clips.

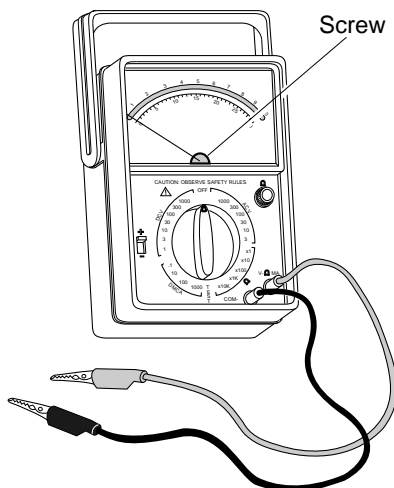

Typical Ohmmeter

2. Calibration

- A. Zero meter - connect the alligator clips to each other. The meter pointer should move to far right of ohms scale (see Figure B).
- B. Use the OHM thumb adjustment knob to set the pointer at the "0" mark on the scale. If pointer will not zero, replace battery.

Note: If you are using a digital readout ohmmeter, calibrate according to manufacturer's instructions.

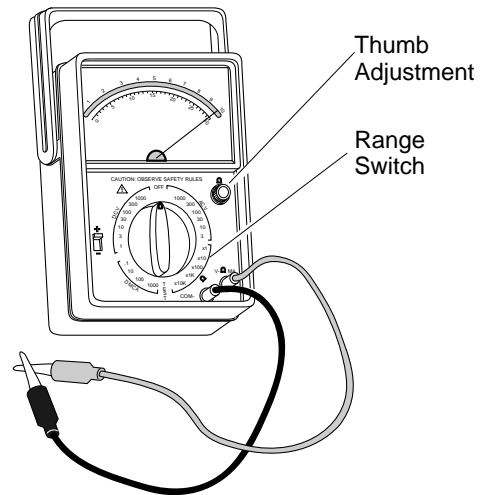

IV. DIAGNOSTIC CHARTS

The following pages contain various diagnostic charts. To use the charts, find the "Observed Fault" that exists and follow test procedure.

Observed Fault Index

Motor starts-Unit does not ignite	11
Motor does not run or runs at slow speeds. Spark is observed at plug	14
Heater does not start/motor and transformer does not operate	17
Heater ignites and burns; However, Safety control trips and heater shuts off	19
Frequent plug fouling/delayed ignition	22

Spark Plug Ignition Models Service Manual

OBSERVED FAULT

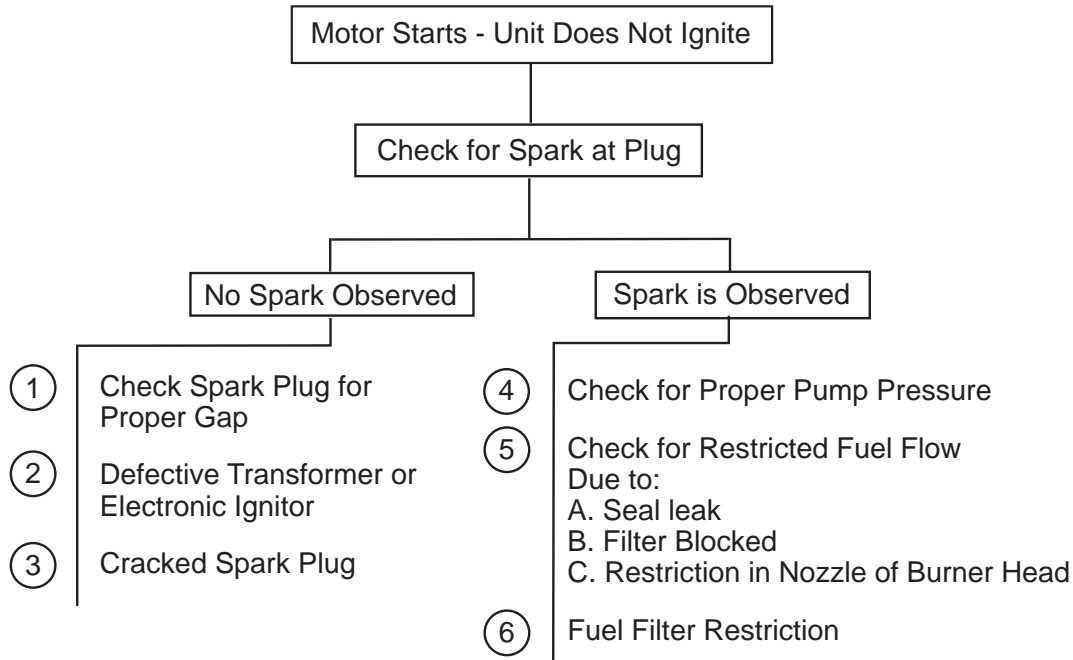

TEST PROCEDURE

① Check Spark Plug for Proper Gap

See *Heater Performance Specifications "Spark Plug Gap"*, page 6, for proper gap. Reset gap with feeler gauge.

② Defective Transformer or Electronic Ignitor

Connect the transformer or electronic ignitor to a properly gapped spark plug. Establish a good ground between the spark plug and heater. Plug in the heater cord and observe for spark between electrodes. If the ground is good and a spark does not jump the gap, the transformer or ignitor is defective.

CAUTION: DO NOT LET ANY PORTION OF YOUR BODY TOUCH ELECTRODES OR PLUG, DUE TO HIGH VOLTAGE.

③ Cracked Spark Plug

During the above test, if spark is observed at any portion of the plug, except at the electrodes, the porcelain insulator is cracked and the plug must be replaced.

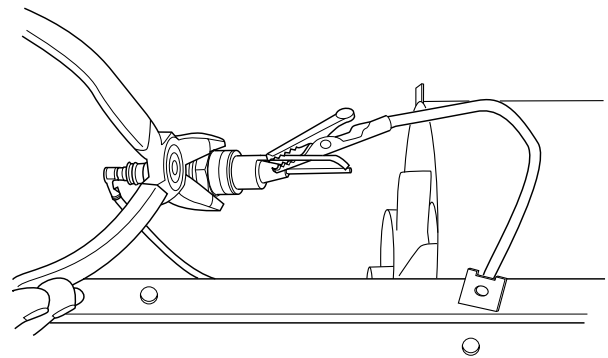
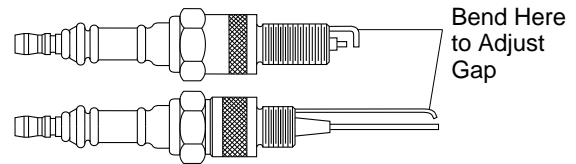

Spark Plug Ignition Models Service Manual

④ Check for Proper Pump Pressure

Install HA1180 Pressure Gauge or equivalent to rear of air filter housing. Start heater and adjust air pressure to specified pressure. Turning adjustment screw clockwise increases pressure, counterclockwise decreases pressure. The screwdriver must be removed from the slot after any adjustment before taking a reading on the gauge (see *Heater Performance Specifications* on page 6 for specified pressures).

Note: Pressure gauge must be scaled in 1/4 pound increments for accurate measurement.

⑤ Check for Restricted Fuel Flow

Remove the burner head from heater. Using a socket wrench, carefully remove the nozzle from burner head. (Be extremely careful not to scratch or score the face of the nozzle).

A. Seal Leak

Remove the rubber seal washer from stem of nozzle and discard. (To be safe, always replace nozzle sleeve during servicing of burner head). Even the smallest air leak in this area can reduce flow rates and result in problems.

Note: On smaller heaters (30,000, 35,000, 50,000, and 55,000 BTU), inspect "O" ring, do not remove.

Install a new rubber seal to stem of nozzle. Make sure the seal washer, spring and second seal washer are in place before reinstalling nozzle in the burner head.

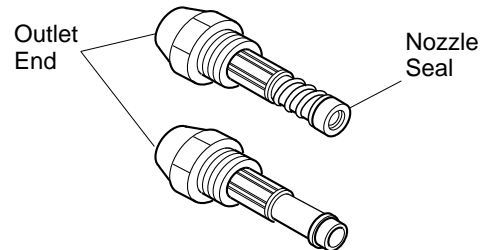
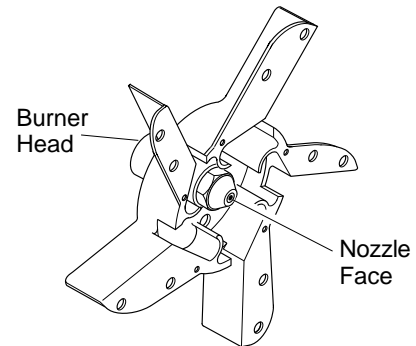
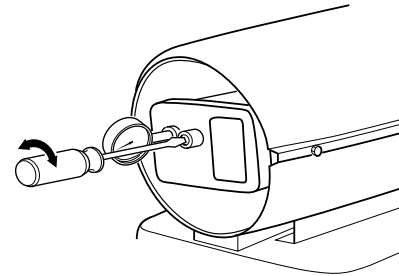

Spark Plug Ignition Models Service Manual

B. Filter Blocked

On certain models, a drop-in fuel filter is located in the copper or aluminum line that attaches to the fuel fitting on the back side of the burner head. Lift the filter out of the copper or aluminum fuel line and clean, if necessary.

C. Restriction in Nozzle or Burner Head

Using a compressed air source, blow the compressed air through the outlet end of nozzle to dislodge any possible restriction.

CAUTION: NEVER DRILL OUT OR TRY TO INCREASE NOZZLE SIZE.

Using compressed air, also blow through passages in burner head. The air should be directed from input fitting at rear of head to the center of burner head. Many times the restriction to the flow is due to metal chips, etc. being present in the burner head assembly.

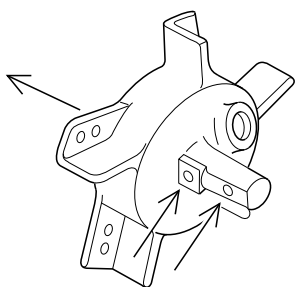
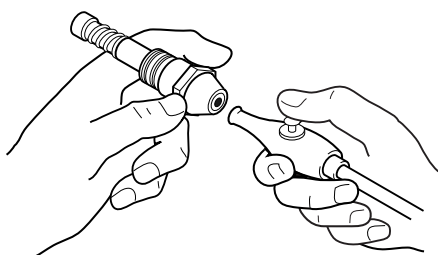

⑥ Fuel Filter Restriction

The fuel filter should be inspected and cleaned. The filters are located in the fuel line either at tank location, in the copper or aluminum tubing or in line with the fuel line at access cover.

Fuel Filter, Bushing, and Lower Fuel Line

Note: Fuel Filter Location May Vary According To Model

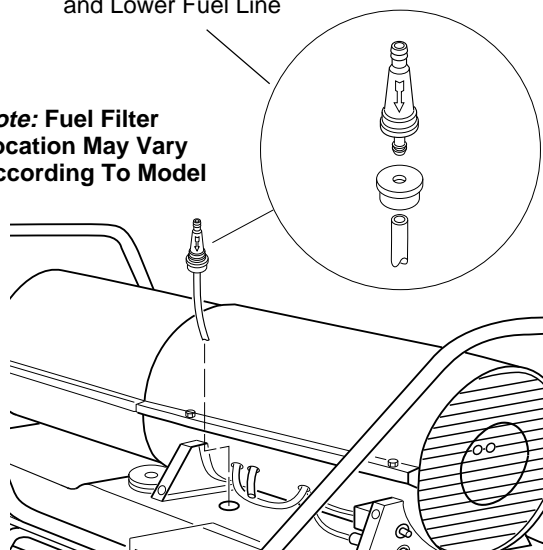

Spark Plug Ignition Models Service Manual

OBSERVED FAULT

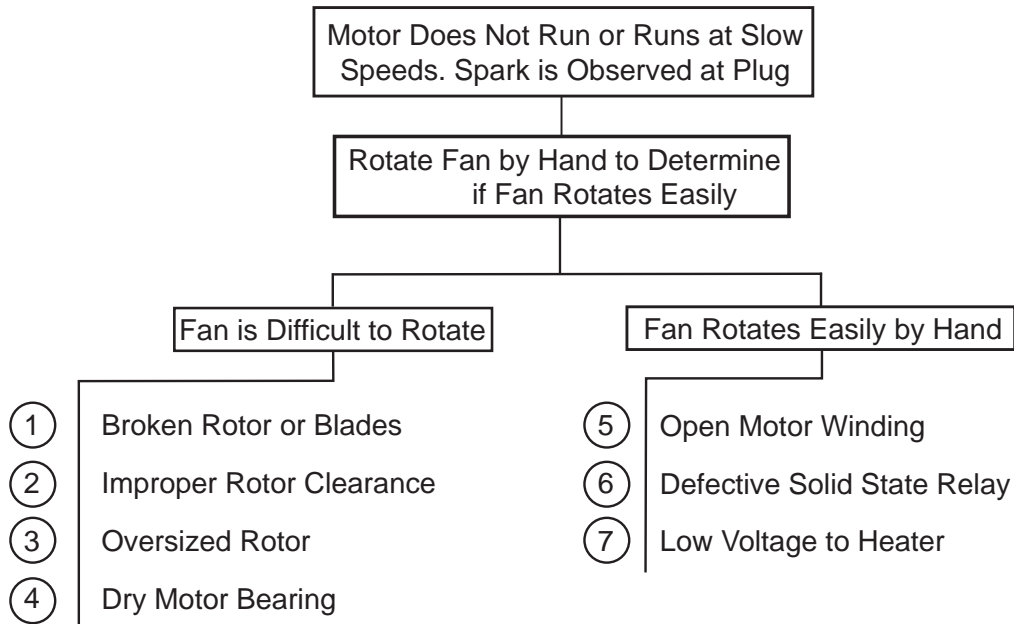

TEST PROCEDURE

① Broken Rotor or Blades

Disassemble the end cover filter and end pump cover from rear of motor. Visually inspect the rotor and blades for breakage. Make sure that the rotor and blades are free of any type of lubricant. Rotor and blades must be clean and dry for proper operation.

② Improper Rotor Clearance

Check rotor with feeler gauge for proper clearance between rotor and pump body. Rotate rotor and make sure all four quadrants of rotor have adequate clearance.

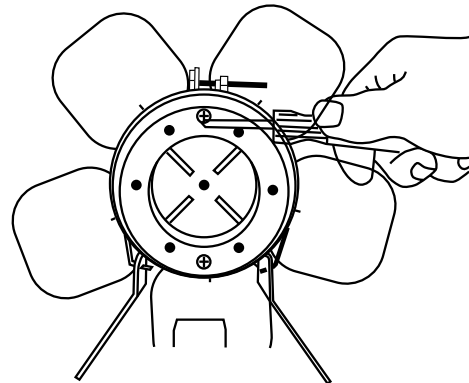
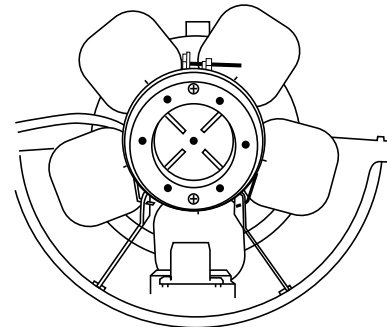

Spark Plug Ignition Models Service Manual

③ Oversized Rotor

If the fan is hard to turn when the motor end cover is installed, but easy to turn when loosened, the rotor should be removed and lightly sanded. Remove the rotor and lightly sand by placing rotor in the palm of hand and sanding on a flat surface making figure eight rotations. (Use the finest grade of sandpaper available).

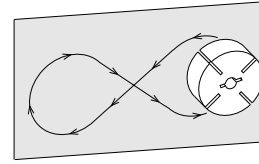

④ Dry Motor Bearing

If the fan is difficult to turn with air pump parts removed, apply 8 to 12 drops of a non-detergent oil to the sleeve bearing on the fan of the motor. The bearing located at the pump end is of the ball bearing type and should not be lubricated. **DO NOT OIL PUMP END BEARING.**

Note: Motor manufactured after 1978 have permanently lubricated sleeve bearing and cannot be oiled

Oil fan-end motor bearing here

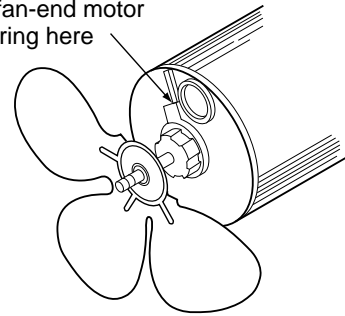

⑤ Open Motor Windings

Motors Without Relay (30,000, 35,000, 50,000, and 55,000 BTU)

With the heater disconnected from AC plug, connect the ohmmeter on the RX1 scale to the wires coming from motor. On smaller heaters, the leads from the motor should indicate a resistance of 6 to 8 ohms. Actual resistance varies between motor types.

Note: Resistances may vary due to motor temperature.

Motors with Relays (70,000, 100,000, 110,000, 150,000, 165,000, and 200,000 BTU)

Start Winding

Connect the ohmmeter on the RX1 scale to the white and black wires coming from motor. This procedure allows you to determine the condition of the start winding. If the meter indicates infinity (open circuit) or the meter goes full scale (zero ohms), the winding is defective and the motor must be replaced. Actual resistance varies between motor types.

Main Winding

Connect the ohmmeter on the RX1 scale to the red and white wires coming from motor. If the needle does not move again or goes to full scale, the motor must be replaced. Actual resistance varies between motor types.

Note: Motor may vary according to model

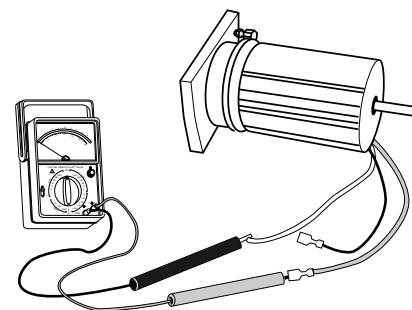
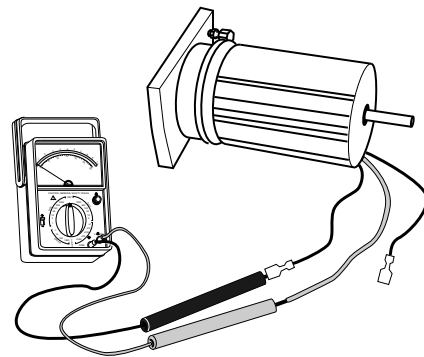
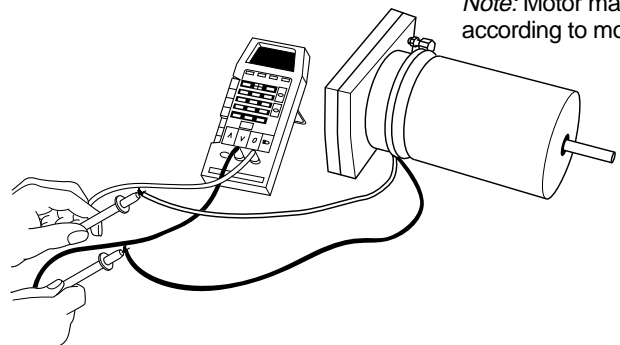

Spark Plug Ignition Models Service Manual

⑥ Defective Solid State Relay

Defective Solid State Relay

Prepare a jumper wire approximately 8" long with a male quick disconnect terminal at one end and a test probe at the other end. Disconnect the black wire coming from the motor that is connected to the solid state relay terminal. Connect this black wire to the male connection of jumper wire. Touch the test probe to the opposite terminal of the solid state relay and plug in the heater. As soon as the motor reaches speed, remove the test probe from terminal. The motor should continue to run. If the motor operates correctly, the solid state relay should be replaced.

CAUTION: DO NOT TOUCH ELECTRICAL CONNECTIONS OR ALLOW THEM TO TOUCH METAL PARTS OF THE HEATER.

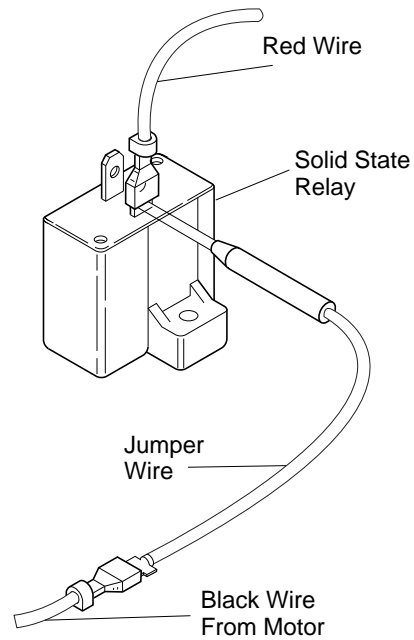

⑦ Low Voltage to Heater

In certain circumstance, a heater may operate correctly when being tested in the service shop, but the customer complains that it does not start at times on the job site. It is important that the customer is made aware that if the heater is operated on an incorrectly sized extension cord or a low voltage outlet, the heater's motor will not start due to low voltage. If the customer has the availability of a voltmeter, have the customer check the voltage at the heater. A minimum of 108 volts, while the heater is running, is necessary for proper operation. Refer to the Electrical Section of this manual (page 5) for proper extension cord sizing.

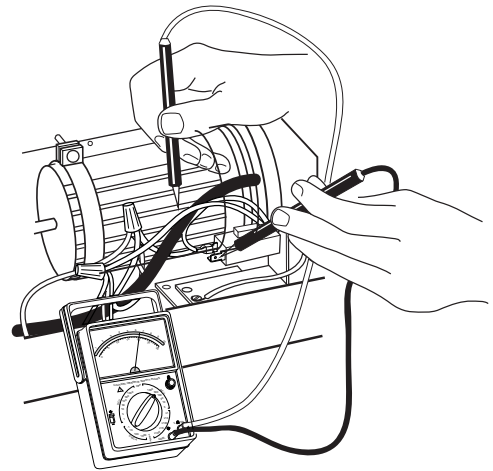

OBSERVED FAULT

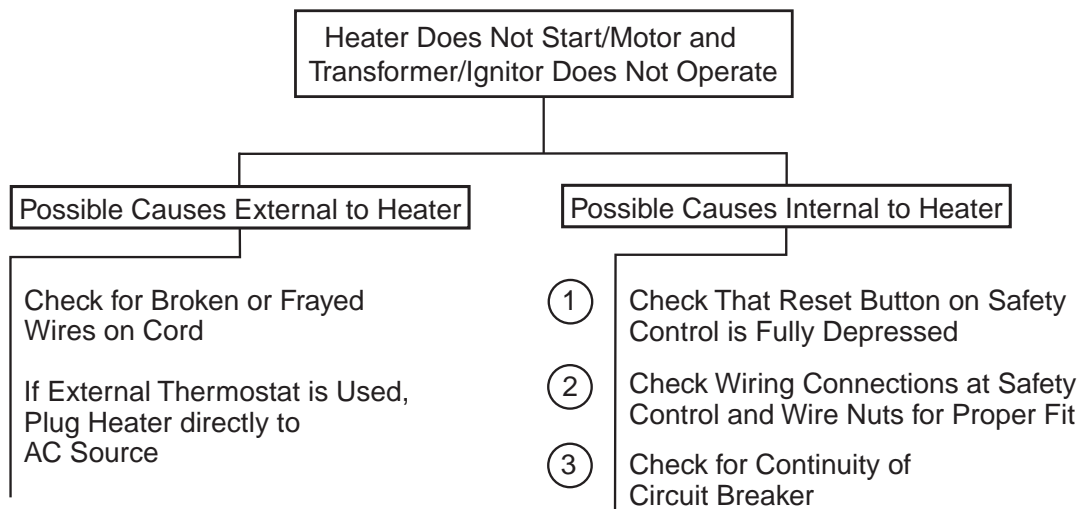

TEST PROCEDURE

① Check That Reset Button on Safety Control is Fully Depressed

Visually inspect the black reset button on safety control. The button must be fully depressed and latched in for operation.

② Check Wiring Connections at Safety Control and Wire Nuts for Proper Fit.

Wire Nuts

Physically check electrical connections at wire nuts and safety control for proper fit. Check for continuity between male prongs of power cord to safety control.

Terminal Board

Make sure connections are secure.

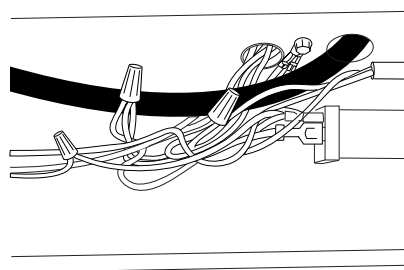
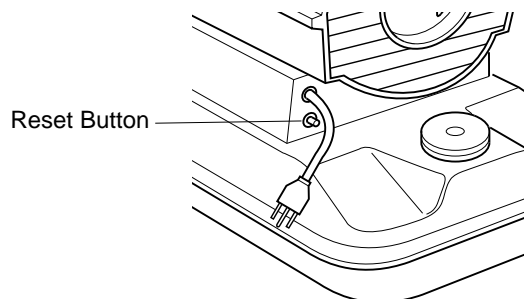

Spark Plug Ignition Models Service Manual

③ Check for Continuity of Circuit Breaker

A. Standard Safety Control PP203 (098205-04)

With the heater disconnected from AC source, disconnect the red and black wires connected to the safety control. Push reset button in. With the ohmmeter on the 0 to 200 OHM scale, check for continuity across terminals where wires were removed. Meter should indicate "0".

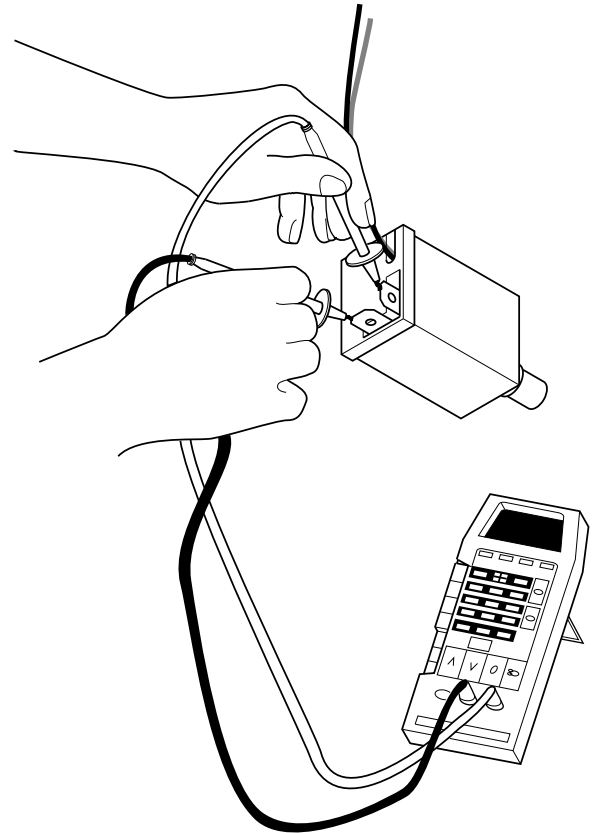
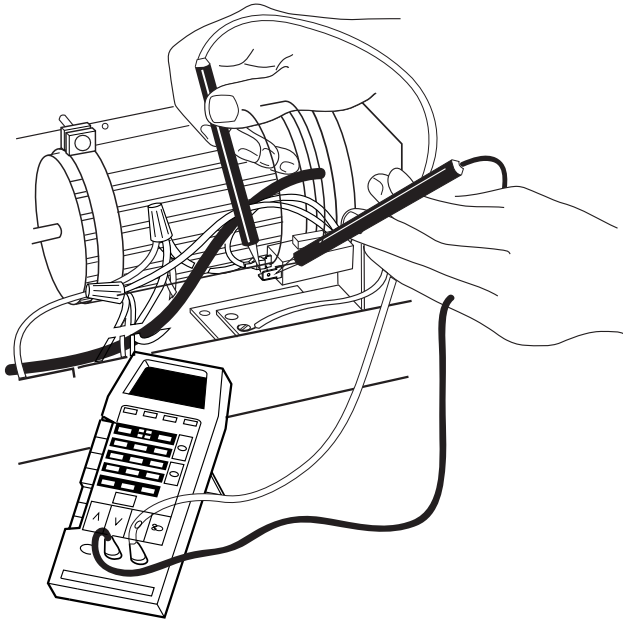

Spark Plug Ignition Models Service Manual

OBSERVED FAULT

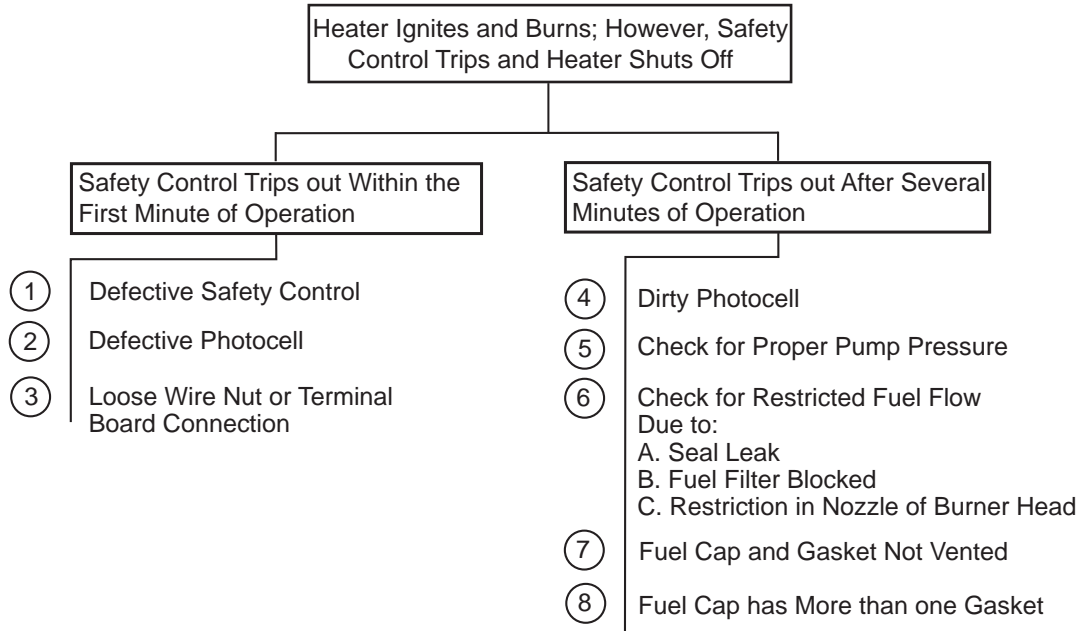

TEST PROCEDURE

① Defective Safety Control

PP203 (098205-04)

Make sure unit is disconnected from AC source. Disconnect the blue wire coming from safety control that is connected to blue wire at photocell (connection is made in smaller wire nut connection).

Connect the blue wire from control under the wire nut connection where the white wires are connected. Plug unit into AC supply. If the reset button on the safety control pops out and unit shuts off, the control is defective and must be replaced.

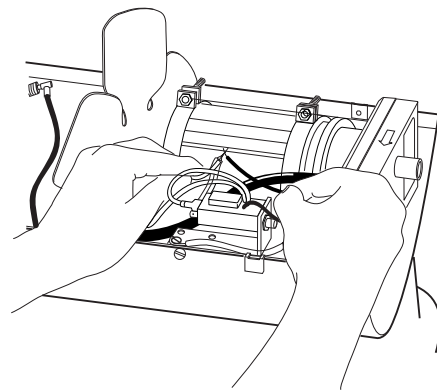
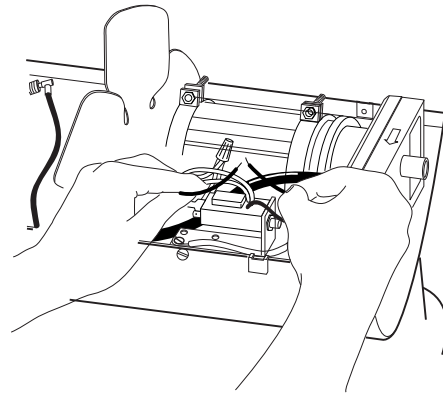

Spark Plug Ignition Models Service Manual

② Defective Photocell

Inspect the lens of the photocell for soot/dirt, etc... If dirty, wipe off with a clean, damp cloth.

Remove photocell from heater and connect ohmmeter on the 1000 Ohm (RX1K) scale. Hold the lens up to a light source (60 watt light bulb, direct sunlight, etc.) with the lens of the photocell pointed toward the light source. The resistance of the meter should be low (less than 500 ohms).

By blocking off the light source by putting thumb over opening of photocell, the resistance on meter should be high. Replace the photocell if a change in resistance is not observed during the above test.

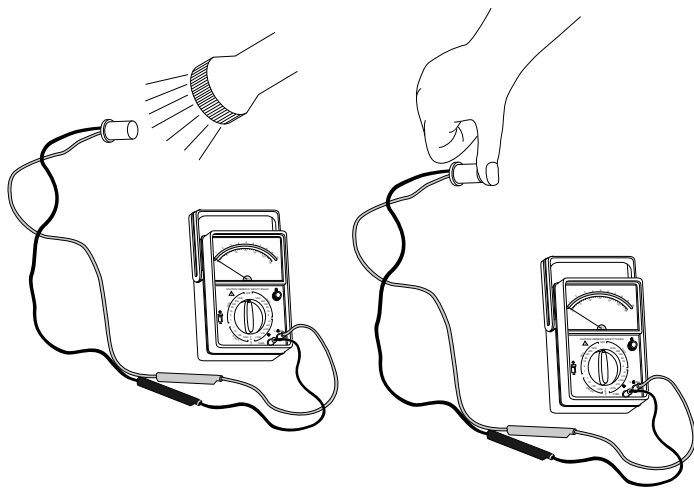
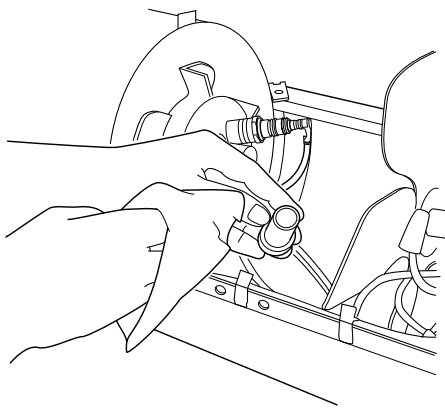

③ Loose Wire Nut or Terminal Board Connection

Physically check that all electrical connections are secure and making electrical contact.

④ Dirty Photocell

See step #2, column 1.

⑤ Check for Proper Pump Pressure

Install HA1180 Pressure Gauge or equivalent to rear of air filter housing. Start heater and adjust air pressure to specified pressure. Turning adjustment screw clockwise increases pressure, counterclockwise decreases pressure. The screwdriver must be removed from the slot after any adjustment before taking a reading on the gauge. (See *Heater Performance Specifications* on page 6 for specified pressures).

Note: Pressure gauge must be scaled in 1/4 pound increments for accurate measurement.

⑥ Check for Restricted Fuel Flow

Remove the burner head from heater. Using a socket wrench, carefully remove the nozzle from burner head. (Be extremely careful not to scratch or score the face of the nozzle).

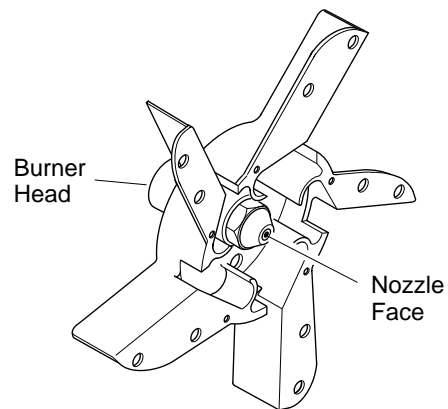
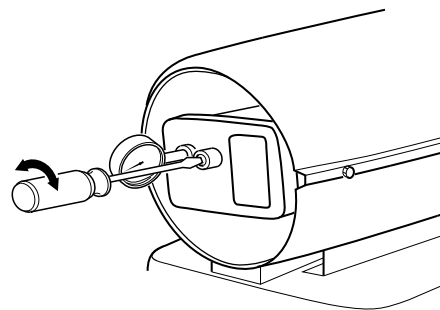

Spark Plug Ignition Models Service Manual

Restricted Fuel Flow cont.

A. Seal Leak

Remove the rubber seal washer from stem of nozzle and discard. (To be safe, always replace nozzle sleeve during servicing of burner head). Even the smallest air leak in this area can reduce flow rates and result in problems.

Note: On smaller heaters (30,000 thru 55,000 BTU), inspect "O" ring, do not remove.

Install a new rubber seal to stem of nozzle. Make sure the seal washer, spring and second seal washer are in place before reinstalling nozzle in the burner head.

B. Fuel Filter Clogged

Clean or replace fuel filter as necessary.; filter is located at lower end of fuel pickup tube on 30 thru 70 and 200 models. Filter is located on top of fuel tank on 100 thru 165 models. On 200 model the filter is located at the end of fuel line inside fuel tank.

C. Restriction in Nozzle or Burner Head

Using a compressed air source, blow the compressed air through the outlet end of nozzle to dislodge any possible restriction.

CAUTION: NEVER DRILL OUT OR TRY TO INCREASE NOZZLE SIZE.

Using compressed air, also blow through passages in burner head. The air should be directed from input fitting at rear of head to the center of burner head. Many times the restriction to the flow is due to metal chips, etc. being present in the burner head assembly.

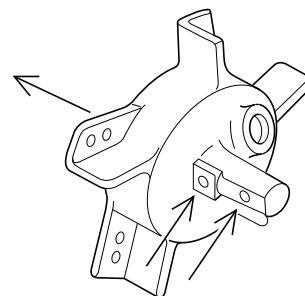
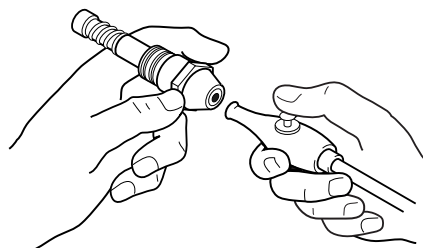
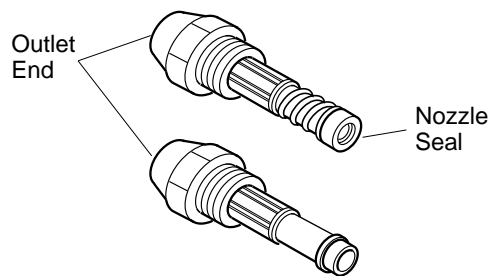

Fuel Filter, Bushing, and Lower Fuel Line

Note: Fuel Filter Location May Vary According To Model

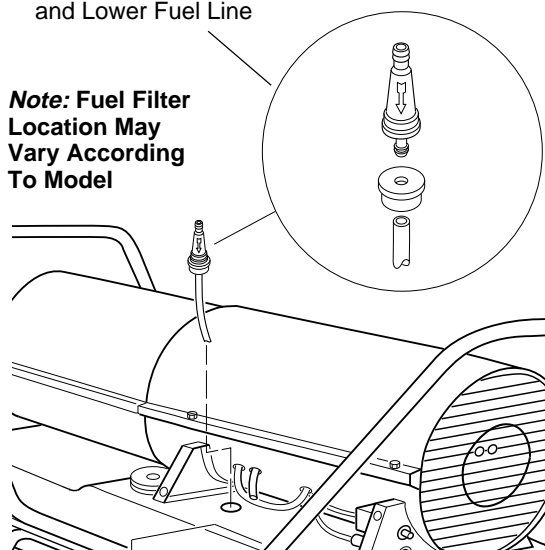

Spark Plug Ignition Models Service Manual

⑦ Fuel Cap and Gasket Not Vented

Inspect the vent hole and gasket under the fuel cap to make sure the passage is open. Remember that since the fuel is being drawn from the tank, the tank must be vented for proper operation.

⑧ Fuel Cap Has More Than One Gasket

Make sure cap has only one gasket installed.

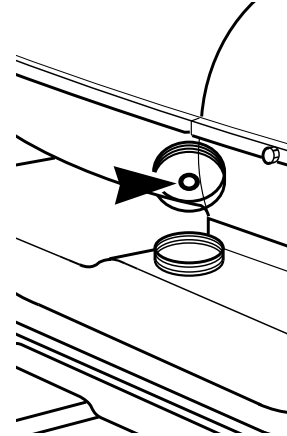

OBSERVED FAULT

Frequent Plug Fouling/
Delayed Ignition

- ① Spark Plug Too Close to Spray Pattern of Nozzle
- ② Wrong Fuel

TEST PROCEDURE

① Spark Plug Too Close to Spray Pattern of Nozzle

It may be necessary in some cases to move the spark plug back from spray pattern of nozzle. The best method is to shim the plug back by placing a standard spark plug washer under the flat of the plug at threaded area. This moves the plug back approximately .1 inch and reduces the possibility of the plug fouling with carbon or the plug becoming wet during the ignition cycle.

② Wrong Fuel

Refer to *Fuel Selection* on page 5 of this manual.

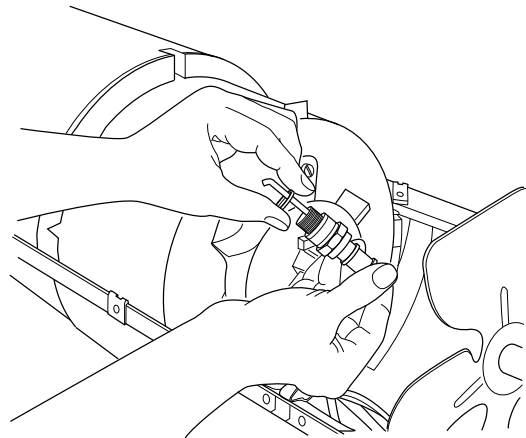

Spark Plug Ignition Models Service Manual

DIAGRAMS AND CHARTS

I. WIRING DIAGRAMS

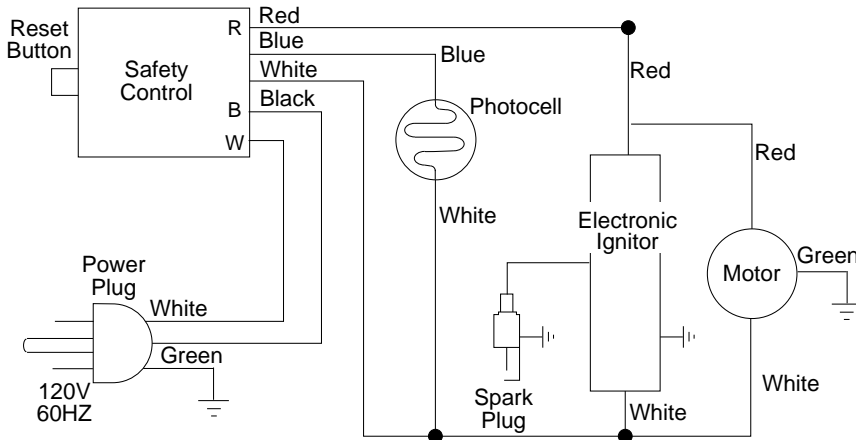

30,000, 35,000, 50,000, & 55,000 BTU Heaters

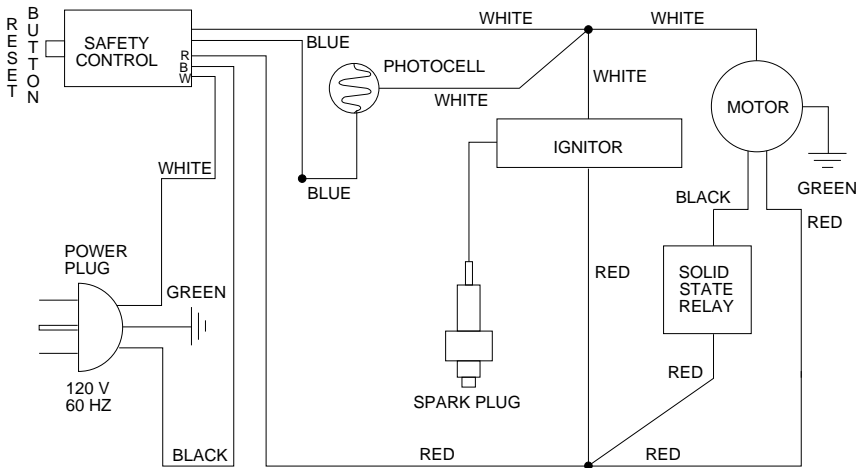

70,000 - 200,000 BTU Heaters - Heaters Equipped With Solid State Relay

II. MOTOR RESISTANCE CHART

MOTOR	OHMS	
	RED TO WHITE MAIN ($\pm 7\%$)	BLACK TO WHITE AUXILIARY ($\pm 7\%$)
100088-01	6.2	—
097130-02	7.5	16.5
097134-02	3.5	18.3
101898-01	2.8	9.1

DESA
INTERNATIONAL

079337-01
Rev. D
08/00

For replacement parts contact:

www.PartsFor.com